



PRODUCT CATALOGUE
for CO₂ Capture / Recovery Process

CARBON ATOM

OXYGEN ATOM

OXYGEN ATOM





INTRODUCING

Hisaka Works proudly presents a plate heat exchanger to save more energy and lower the production cost of processes. The SX-80 series. Carbon dioxide capture and recovery has been a very preferable process as it reduces carbon dioxide pollution and the recovered carbon dioxide can then be used for many other applications. Such is a truly 'green' idea of the 21st century. With the use of HISAKA SX-80 series, these process can happen more effectively, more productively, and most importantly, less costly.

REDUCE
CO₂
POLLUTION



RECOVER
CO₂



REDUCE
GLOBAL
WARMING



SX-80 Series

With the high NTU (Number of Transfer Units), SX-80 is still able to upkeep the heat transfer performance.



Contributing to the new environment with the new advanced GREEN technology. There are several methods in recovering CO₂, which the more popular method in the market is chemical adsorption using AMINE solution.

When lean amine contacts with the gas released (which contains CO₂), CO₂ is selectively adsorbed by lean amine. After the adsorption, lean amine becomes rich amine and is sent to a stripper for the release of CO₂. In this process, rich amine shall be heated up and lean amine shall be cooled down. HISAKA can proudly provide our SX-80 for this application, being the vital tool in exchanging the heat between rich and lean amine, minimizing the overall energy consumption. SX-80 series is a specially developed Plate Heat Exchanger for CO₂ recovery process. Due to the unique design of the gasket made of a special composition, its gasket life is prolonged and lasts longer than previous designs. In addition, adopting the new advance plate corrugation pattern can improve the performance of heat transfer. As a result, SX-80 can save the maintenance cost, shorten the plant's downtime, minimize the consumptions, and ultimately maximize the productivity.



PLATE HEAT EXCHANGER for Co2 Capture / Recovery Process



for CO2 Capture /
Recovery Process

www.hisaka-asia.com

SX-80 series dramatically improves operation efficiency through its innovative plate design and gasket improvements of more stability to amine solutions.

Hisaka Works, Ltd. has supplied a number of Plate Heat Exchangers at gas refinery plants where amine solutions are used. Our SX-80 series contributes to realization of running cost reduction and stable operation of the plants, through the adoption of further high-performance heat transfer chevron patterns to suit its heat recovery operation conditions as well as the new development of more stable gaskets to amine solutions.

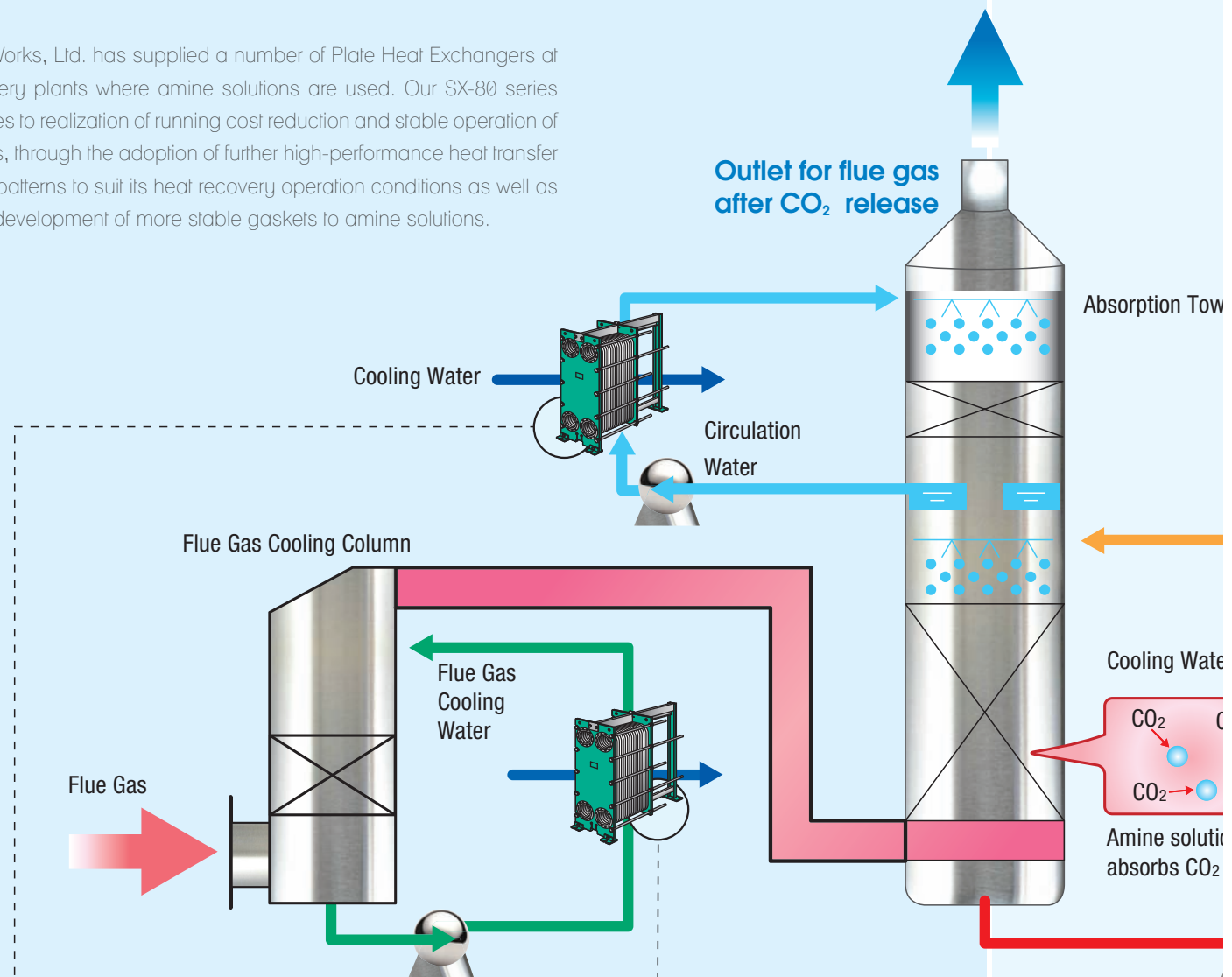

**ABSORPTION
TOWER
CIRCULATION
WATER
COOLER**

Plate Heat Exchangers are to cool top circulation water to cool flue gas from Absorption Tower.

**FLUE GAS
COOLING
COLUMN
WATER COOLER**

Plate Heat Exchangers are to cool cooling water used to cool high-temperature flue gas.



RICH/LEAN AMINE HEAT EXCHANGER

Amine solution (generally called Rich Amine) where CO₂ is absorbed at Absorption Tower needs to be heated in order to release CO₂ at Regeneration Tower. Plate Heat Exchangers are normally used for heat recovery, to then reduce the volume of steam for the Regeneration Tower by use of heat of Amine solution (generally called Lean Amine) that CO₂ has been released.

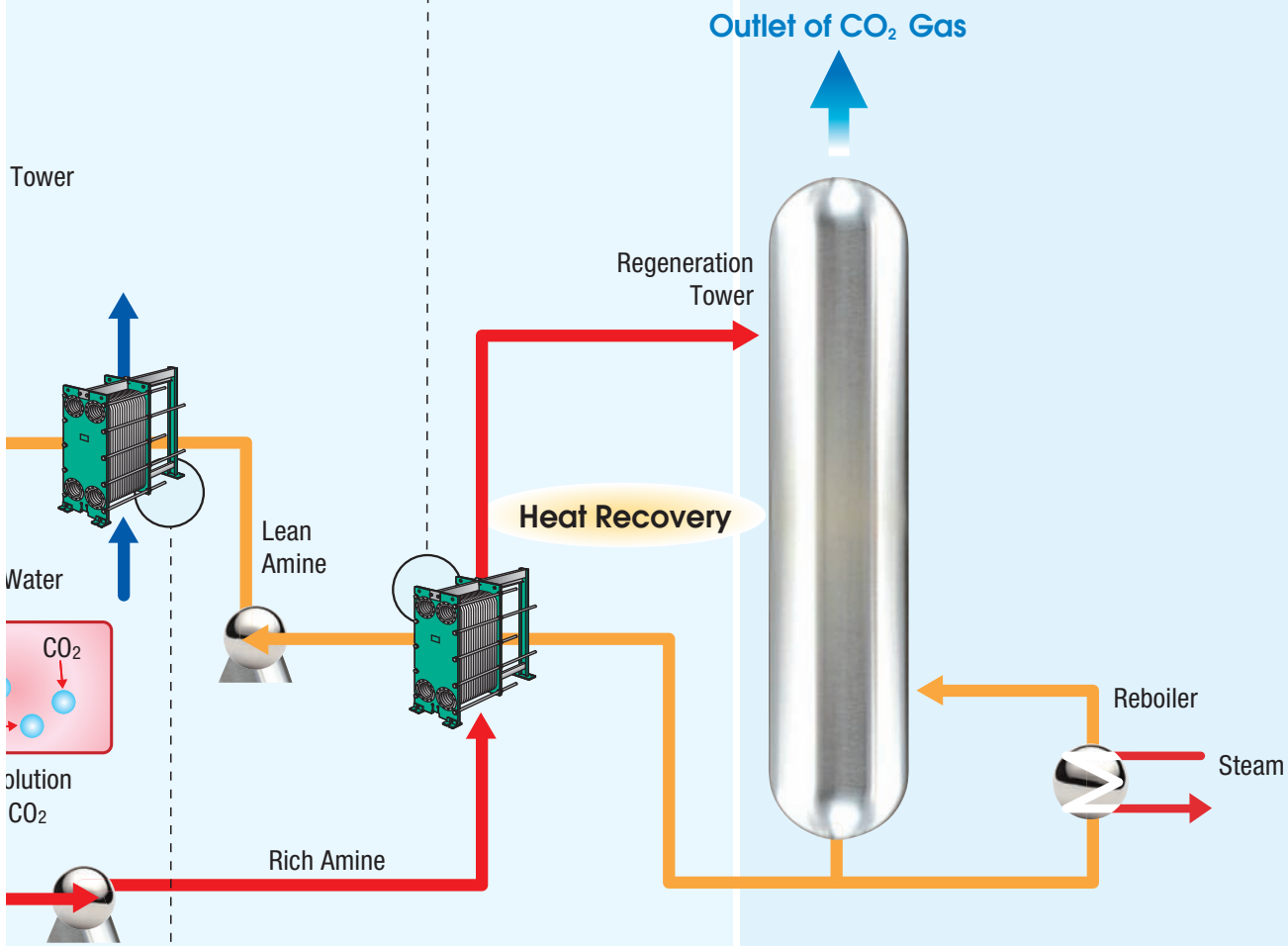

LEAN AMINE COOLER

Plate Heat Exchangers are to cool amine solution (Lean Amine) from which CO₂ is removed, in order to return to Absorption Tower.

Features of SX-80 Series



1 PLATES :

a marvelous level of heat recovery as well as stable sealing performance at this temperature range

Our SX-80 series adopts the most suitable plate design for higher NTU for amine operation conditions of Lean/Rich Amine heat recovery. These plate series are developed, by use of our whole thermal and hydraulic knowledge that we've got ever through our long experiences, to feature the highest heat transfer performance with less pressure drop. By this, Rich Amine will be able to be heated up by Lean Amine, then steam consumption required at Regeneration Tower will be able to be extremely reduced. At the same time, Lean Amine will be able to be cooled down, which make cooling water consumption reduce for/at Absorption Tower. Only the SX-80 series allows such highest energy-saving operation with use of the smallest size of Plate Heat Exchangers. Also, Our SX-80 series has a variety of plates to then optimize its design for every specification condition.

On the other hand, SX-80 series has a unique feature of gasket sealing groove to have advantage to maintain stable gasket seals even by swelled gaskets by amine solution.

2 GASKETS :

a characteristic effectiveness to amine solutions themselves and at such higher operation temperatures

Desirable features for gaskets of Lean/Rich Amine Heat Exchangers are both swelling-resistant performance to amine solutions and higher temperature resistance at approx. 130°C at CO₂ regeneration(desorption). Most effective compounds of gaskets are adopted in our SX-80 series gaskets for more stable sealing performance.

3 CONSTRUCTION :

easy maintenance by dismantle, as like conventional Gasket-type Plate Heat Exchangers

Flue gas normally contains a bit hydrocarbon content like a soot, and Rich Amine after Absorption Tower (CO₂ rich) may make plate surface fouled and dirty. In order to make continuous operation efficiently, therefore, periodical maintenance by complete cleaning is required.

SX-80 Series is possible to be dismantled and manually cleaned plate by plate, and at the same time visually checked, same as conventional Gasket-type Plate Heat Exchanger, while Shell-and-Tube Heat Exchanger and welded type Plate Heat Exchanger (incl. semi-welded type) seem to be difficult in dismantling.

4 INITIAL COST-SAVING : further compact and light-weighted size

In addition to smaller heat transfer area, due to highest thermal performance (heat transfer co-eff.), higher pressure-resistance is achieved by unique plate and sealing design, although this amine process operates at high temp., rather than conventional Gasket type Plate Heat Exchanger. By this, the SX-80 series enables further compact and light-weighted size.

Moreover, our SX-80 series is capable of design optimization for every specification from three different patterns. As the result, it will realize initial cost-saving for new PHE units themselves as well as for easy handling and installation.

[Dimensional Information]

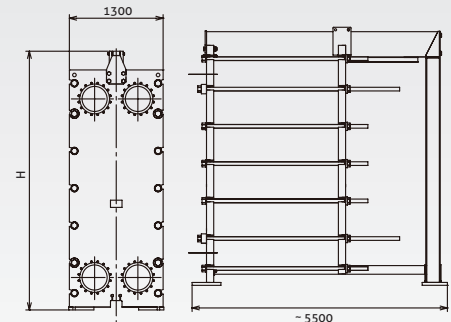

Heat Transfer Area: 150 ~ 2200m²

Dimension:

Type	H mm
SX-80S	3000
SX-80M	3600
SX-80L	4200

Connection: 350mm / 14" or less

5 OPERATIONAL COST-SAVING :

Not only extreme steam consumption reduction at Regeneration Tower for heating up, as stated in Feature 1, but also less maintenance frequency due to stable gasket sealing performance will contribute to enormous operational cost-saving.

$$NTU = U \cdot A / G \cdot C_p \cdot \Delta t_{lm}$$

U : Overall heat transfer coefficient

A : Heat transfer area

G : Flow rate of fluid

C_p : Heat capacity of fluid

Δ t : Temperature change in one fluid

Δ t_{lm} : Logarithmic mean temperature difference between hot and cold side

$$NTU = \frac{\text{Temperature change}}{\text{Logarithmic mean temperature difference}} = \frac{70}{10} = 7.0$$

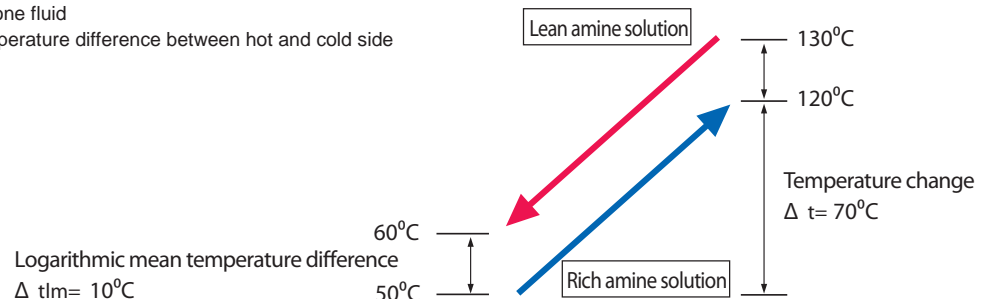

PRODUCT CATALOGUE

for CO2 Capture /
Recovery Process



**WE are
HERE**

HISAKA, YOUR TRUSTED ASIAN BRAND

www.hisaka-asia.com

HISAKAWORKS S.E.A SDN BHD

Company No. 671059-K
(South East Asia Headquarters)
No 2, Jalan TP 2, Taman Perindustrian SIME UEP,
47600 Subang, Selangor Darul Ehsan, Malaysia
Tel : +603 5880 4185
Fax : +603 8081 7185
Email : heatexc@hisaka-asia.com

HISAKA WORKS, LTD

OSAKA : 2-1-48, Higashi-konoike-cho
Higashi-Osaka, Osaka, 578-0973, Japan
Tel : +81 72 966 9601
Fax : +81 72 966 8923

TOKYO : Kyobashi Om Bldg., 1-19-8,
Kyobashi Chuo-Ku, Tokyo, 104-0031, Japan
Tel : +81 3 5250 0760
Fax : +81 3 3362 2759

HISAKAWORKS THAILAND CO., LTD.

BANGKOK
Phairojkiija Tower, 15th Floor Zone C,
825 Bangna-Trad Road, Kwang Bangna,
Khet Bangna, Bangkok 10260
Tel : +66 2711 3287 - 9
Fax : +66 2744 3286
Email : heatexc@hisaka-thai.com

RAYONG

Eastiny Park 5 Village, 222/36, Moo 10 T.,
Bangsarey A. Sattahip, Chonbouri Province,
20250
Tel : +66 3811 0759
Fax : +66 3811 0796
Email : haetexc@hisaka-thai.com

HISAKAWORKS SINGAPORE PTE LTD (Sales Office)

No. 18, Boon Lay Way, #02-118 Trade Hub 21 Singapore 609966
Tel : +65 6897 8489
Fax : +65 6686 4579
Email : heatexc@hisaka-sing.com

PT HISAKA WORKS INDONESIA

Ruko Puri Botanical, Jl. Raya Joglo, Blok I 10 No 29,
Kebun Jeruk, Jakarta Barat 11640, Indonesia
Tel : +62 051 5890 0090
Fax : +62 051 5890 0091
Email : hisakindo@hisaka-asia.com

HISAVINA (Sales Representative Office)

HO CHI MINH CITY
Hoang Dan Building, 47-49, Hoang Sa Street,
Da Kao Ward, District 1, Ho Chi Minh City, Vietnam
Tel : +84 8 3910 7355
Fax : +84 8 3910 7356
Email : hisavina@hisaka-asia.com

Hanoi

8th Floor, Sannam Building, 78 Duy Tan St.,
Dich Vong Ward, Hanoi, Vietnam
Tel : +84 4 778 9900
Fax : +84 3795 9911
Email : hisavina@hisaka-asia.com

HISAECD (Philippines Representative Office)

One Global Place, 20th Floor, Office Business Center,
25th Street & 5th Avenue, Bonifacio Global City,
Taguig 1632, Philippines
Tel : +632 224 4129
Fax : +632 224 4130
Email : hisapino@hisaka-asia.com



MS ISO/IEC 17021:2011
QS 02032013 CB 13