

# GENERAL CATALOG

— Create the future with heat  
**The Thermal Solution Company**



 **HISAKA**

Heat Exchanger Division

— Create the future with heat

# The Thermal Solution Company

Using plate type heat exchangers as our core technology, we provide thermal solutions to our customers all over the world.



HISAKA WORKS / Konoike Plant



HISAKAWORKS S.E.A. (Malaysia)



HISAKA WORKS (CHINA) CO., LTD. (China)



UX-160, one of the largest plate heat exchangers in the world

**Use it "surely."  
Use it "more."  
Use it "longer" into the future.  
HISAKA continues  
to supply reliable  
plate heat exchangers.**

HISAKA WORKS, LTD. is the largest plate heat exchanger manufacturer in Asia.

By manufacturing and selling plate heat exchangers used in applications such as heating, cooling, sterilization, pasteurization, heat recovery, and condensation in various industrial processes for chemicals, food, air conditioning, marine, pulp and paper, steel / metal and automobile and related. We contribute to the effective use of resources and the improved efficiency of production facilities. We are also actively engaged in overseas expansion. We have established network in Malaysia, Thailand, Singapore, China, South Korea, Indonesia, Vietnam, the Philippines, and Saudi Arabia, and also provide technology to ARSOPI THERMAL (Portugal).



40,000 ton press, one of the largest in the world



Fully-automated 20,000 ton press



High-speed, automated 4,000 ton press

# Design Plate Heat Exchangers Online

Since we delivered our first domestically-produced device in 1953, HISAKA plate heat exchangers have been used in all kinds of industries as compact heat exchangers with maximum efficiency. In order to meet more diverse and more sophisticated needs, we have arranged a rich variety of models, from small models of 0.18 m<sup>2</sup>/unit to large models up to 3,400 m<sup>2</sup>/unit.

## Basic Structure

Heat transfer plates are made by pressing thin sheets of corrosion-resistant metal such as stainless steel or titanium, then set them with seal gaskets and hang and pile them on the guide bar. Then, plates are tightened with bolts between the fixed frame and the movable frame. Here, there is a certain gap between the heat transfer plates that allows liquid to flow. The liquid inlets and outlets are in the fixed frame or the movable frame.



## Heat Transfer Plate

Each heat transfer plate is corrugated to various patterns to increase its strength and surface area. Furthermore, the corrugation makes high turbulence and thereby achieves high heat transfer coefficient. Portholes are formed in the plate's four corners. The gasket is set into the groove around the plate edge to seal in the fluid. (Refer to P7.)

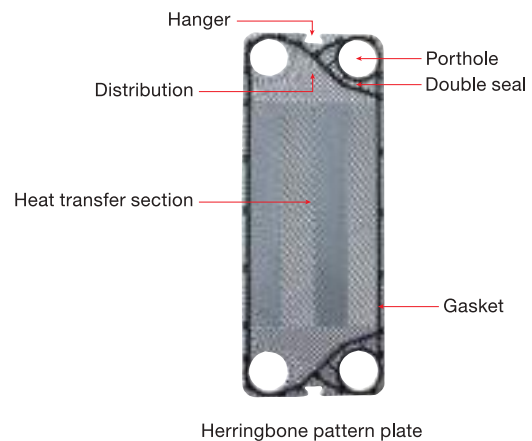

## Flow Channel of Fluid

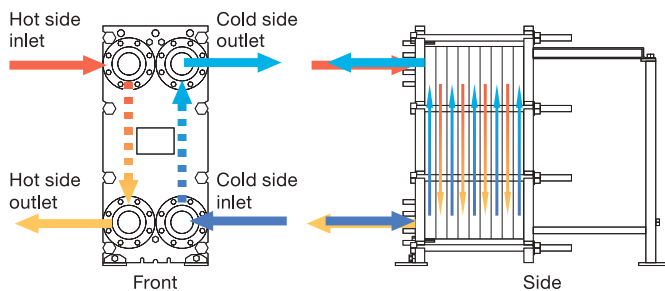

## Structure of a Plate Heat Exchanger (PHE)

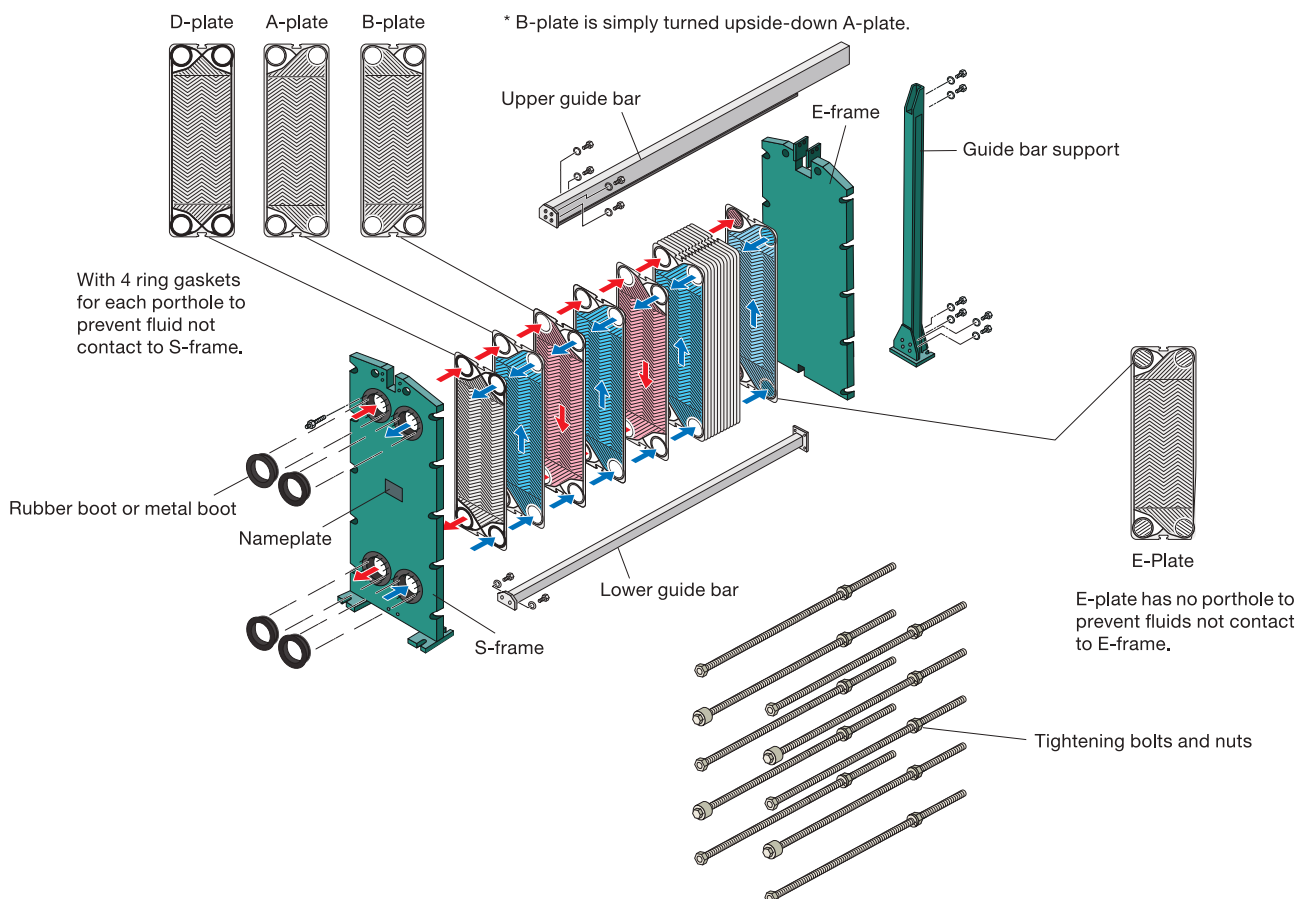

## Standard Operational Data

Processing capacity: 0.1 m<sup>3</sup>/h to 7,300 m<sup>3</sup>/h

Working pressure: max. 4.0 MPaG

Working temperature: max. 180°C

Heat transfer area: 0.18 m<sup>2</sup>/unit to 3,400 m<sup>2</sup>/unit

Plate material:

Stainless steel: 304, 316, 315J1, 317, Etc.

Titanium: TP270, TP270-Pd

High nickel alloy: C-276, C-22, B, G

Nickel: NNCP, NLCP

Other: Domestic and international standard materials

Gasket materials:

NBR, IIR, EPDM, FPM, Silicon,

TCG (PTFE cushion gasket)

\* The above data varies depending on the model, material, plate thickness, and operating specifications.

## PHE Model Numbers

The plate type, thickness, and number, and the frame type for HISAKA PHEs are indicated as below.

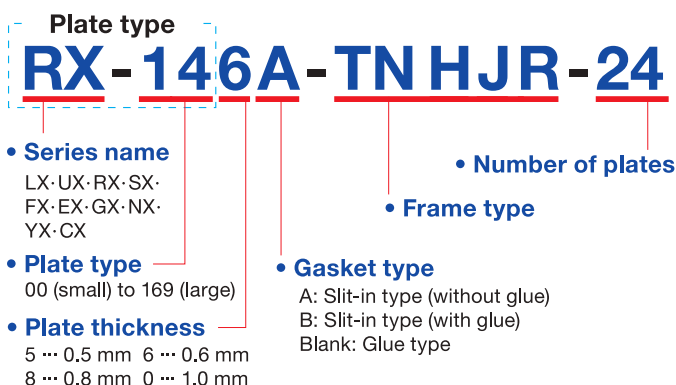

## Pressure Vessel Code and Standard

Our company can design and manufacture plate heat exchangers subject to the following regulations and applications. As certain applications may not be possible depending on the model, material, plate thickness, and other factors, please be sure to inquire with us if regulations may apply.

## Overseas Standards

### ASME STAMP

We can design and manufacture plate heat exchangers in compliance with ASME (American Society of Mechanical Engineers standard), ASME Boiler and Pressure Vessel Code, Section VIII, Division 1.

Note: As the design temperature may be subject to restrictions depending on the aforementioned plate material, plate thickness, and gasket materials, please be sure to inquire with us.



# Features

## High Performance

The overall heat transfer co-efficient (U-value) ranges from 4,000 to 9,000  $W/m^2 \cdot ^\circ C$  in water application, since the plate corrugation provides a highly turbulent flow. This is one of the reasons why plate heat exchangers have such a high heat transfer coefficient. In addition, this turbulent flow also acts to prevent scales on the plate surface.



## Smaller Footprint

The lightweight and compact construction reduces the installation space to 1/3 and the weight to 1/10 of S&T (shell & tube heat exchangers), respectively. In addition, the lightweight and thin heating plates and less liquid hold facilitate the installation work. The Plate Heat Exchanger can be disassembled for cleaning without piping work, while the S&T heat exchanger needs additional space for drawing out the tube bundle.

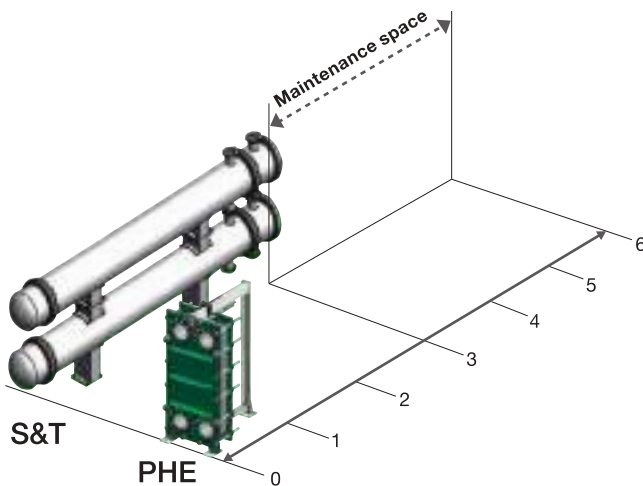

## The terminal temperatures difference up to the limit.

The construction which permits heat exchanging in a perfect counter-current flow with very efficient heat transfer makes it possible to approach a temperature difference between the hot and cold fluids of 1°C or less.

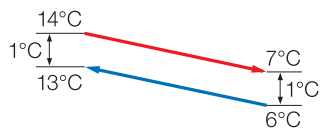

## Line up

We have a rich variety from small to large plate heat exchanger. You can select the most suitable type for your specification requirements.

## Easy Maintenance

Loosening the tightening bolts allows for simple disassembly. The heat transfer plates can be easily inspected visually, and cleaning is easy.

## Steam available as the heat source

The use of a synthetic rubber gasket with a special composition enables the use of steam as a heat source, that is, an operating temperature range up to 180°C.

## Minimal heat radiation

Heat radiation from plate pack is blocked by the gasket, with only a minimal amount of heat radiation from the thin fin-shaped edge. Also, as the front and rear of plate pack is connected to the frame of each through an air layer, the heat radiation is minimal. Except in cases with an extremely small number of plates, it is less than 1% of the heat exchange amount.

## Short delivery time

We have a stock of plates in standard materials (SUS304 / 316 and TP270) and have standardized the construction to achieve short delivery time. However, regarding special materials such as high nickel alloy, NNCP, TP270-Pd, and the like, please inquire.

## Prevention of Liquid Inter-mixing

Special consideration is taken for the gasket so as to protect it from direct contact with the liquid. Furthermore, the gasket is a double-seal type so as to permit liquid draining outside the exchanger even in a case of a liquid leak caused by its deterioration.

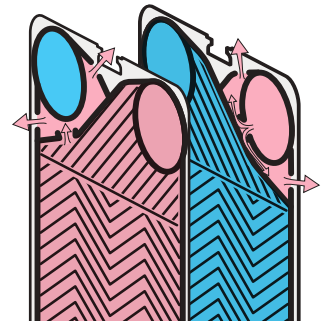

# Plate Element Types

The plates are specially selected from various patterns so as to achieve optimum heat transfer area and cost effective heat exchanger type for each requirement. These plates include the corrugated pattern EX and FX series, the herringbone pattern RX, UX, LX, SX, and CX series, and the specific pattern GX and YX series.

## ■ Corrugated Pattern

The corrugated pattern is also called the wash board pattern. It has less metal contact points between plates and allows for even liquids with fiber or sludge contents to flow easily without blockage. The FX series was developed exclusively for food application even beyond the conventional corrugated pattern. (Refer to P16)



Corrugated

## ■ Herringbone Pattern

The "herringbone" pattern was named as the V-shaped press grooves resemble the bones of a herring. There are numerous contact points by pilling the V-shaped pressed plates, turning them 180° in an alternating pattern. This ensures high pressure resistance, and also the complex flow channels formed by the V-shaped press grooves get high heat transfer performance. Furthermore, including the decreased heat transfer resistance due to the thinner plate results in heat transfer performance three to five times higher than that of S&T heat exchangers.

A herringbone pattern with a W-shaped press groove is called a "double herringbone" and is an improved version of the V-shaped herringbone.

The "lightning herringbone" is a herringbone for higher NTU duty.



Single herringbone

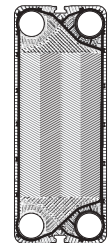

Double herringbone



Lightning herringbone



LX series



RX, UX series

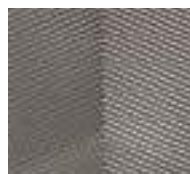

SX series

Pressing depth Deep ←————→ Shallow  
 Pressing pitch Big ←————→ Small  
 NTU Low ←————→ High

## ■ Specific Patterns

In addition to the above plates, we also develop high-functionality plate patterns, such as multi-gap, exclusive condensation use.

## ■ NTU ( $\theta$ )

**NTU = 3 is heat recovery performance of 75%**

The heat transfer characteristic of each plate are expressed using NTU (Number of Transfer Unit,  $\theta$ ) and are defined as follows.

$$\theta = U \cdot A / G \cdot C_p = \Delta t / \Delta t_{lm}$$

U: Overall heat transfer coefficient  
 A: Heat transfer area  
 G: Flow rate of the fluid  
 Cp: Specific heat of the fluid  
 $\Delta t$ : Temperature change of one fluid  
 $\Delta t_{lm}$ : Logarithmic mean temperature difference between  $\Delta t_1$  and  $\Delta t_2$

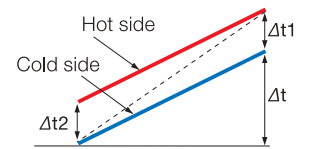

As heat recovery ratio  $\eta$  is expressed as  $\eta = \frac{\Delta t}{\Delta t + \Delta t_{lm}}$   
 when  $\Delta t_1 = \Delta t_2 (= \Delta t_{lm})$ ,  $\theta$  is  $\eta = \frac{\theta}{\theta + 1}$ .

Therefore, for a plate where  $\theta = 3$ ,  $\eta = \frac{3}{3 + 1} = 0.75$ ,  
 which means it has the performance of 75% heat recovery.

## ■ Plate Patterns and NTU

There are two types of herringbone pattern plates; one where the V (W) angle is obtuse (H-plate), and one where it is acute (L-plate). Combining H-plates and L-plates can allow for three types of different flow channels; H-H, H-L, and L-L. Our optimal design method which combines plates, known as the "mixed arrangement," can decrease the heat transfer area by approx. 25% compared to designs with a single plate.

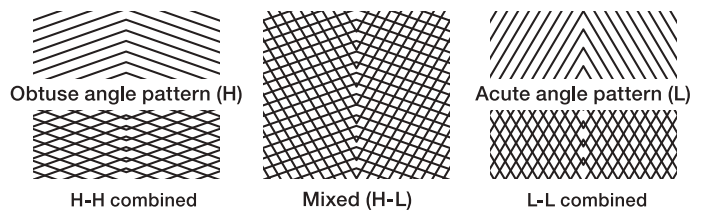

NTU High ←————→ Moderate ←————→ Low  
 Pressure loss Big ←————→ Moderate ←————→ Small

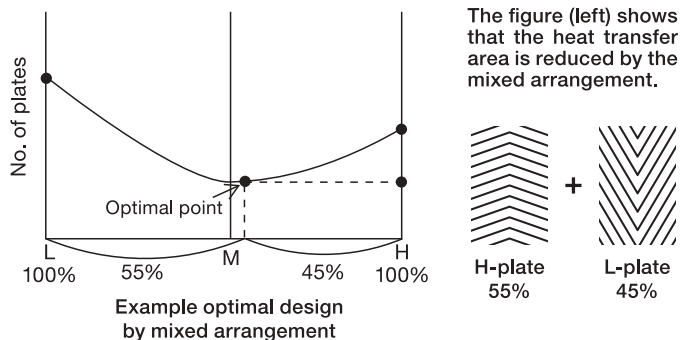

This case shows a mixed arrangement wherein there are 55 H-plates and 45 L-plates for a total of 100 plates. Two plates form one channel, so there are 45 M channels (H-L) and 5 H channels (H-H). The number of plates is significantly reduced compared to a case with only H channels case.

# Gaskets

Gaskets used in plate heat exchangers must have durability in various liquid qualities and temperature / pressure conditions. Hisaka has prepared the following gasket materials in order to support a wide variety of applications.

Standard material: NBR, EPDM (ethylene propylene rubber), IIR (butyl rubber)  
 Special material: FPM (fluororubber), silicon, PTFE cushion gasket

## 1. Slit-in Gasket (Glue-free type)

These plate gaskets do not need glue. The slit-in gasket is especially recommended for those applications where frequent replacement of the gasket is required. Further, without the glue, glue odor is reduced. The slit-in type gasket is suitable for applications such as water treatment or food processing. (D-plate gaskets and distance piece gaskets use glue. Also, some plates do not support slit-in gaskets.)

### Installation of Slit-in Gaskets

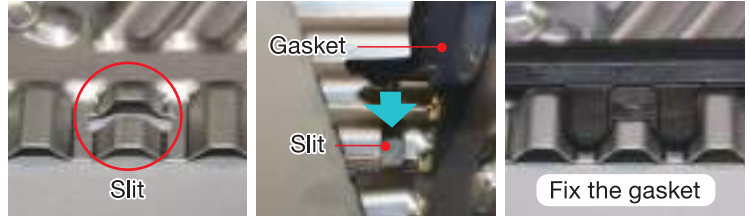

## 2. NEW-EPDM (N-EPDM)

Usually, EPDM gasket is selected either for high temperature or aggressive fluid applications. Although EPDM gaskets are high quality, rubber gaskets lose elasticity as time passes. A cutting edge N-EPDM gasket, newly developed by Hisaka, was introduced. The N-EPDM gasket improves both the heat and chemical resistance. The life-time is two times higher than conventional EPDM. Originally invented specifically for the CO2 chemical recovery process, the N-EPDM is useful for other applications with many advantages.

### Life time of NEW-EPDM and EPDM (180°C)

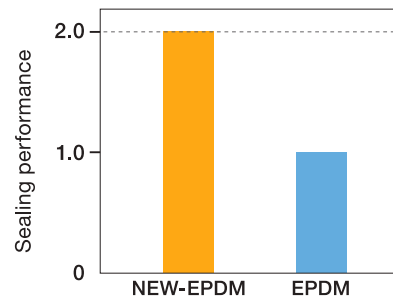

The above compares the sealing performance of the conventional EPDM and the NEW-EPDM. The NEW-EPDM can realize a better heat resistance compared to the conventional EPDM and achieves long time operation.

## 3. PTFE Cushion Gaskets (TCG)

Through our own development, HISAKA has pioneered PTFE Cushion Gaskets for the Plate Heat Exchanger. It is normally used in applications where conventional synthetic rubber would have limitations due to the corrosiveness of the fluid being handled. With this new development, the Plate Heat Exchangers can be applied in a wider variety of applications than before due to the chemical resistance and the durability of PTFE. Due to the elastic core of the TCG gasket, it does not require strong tightening torque during the assembly of the unit. Thus, it reduces the risks of plate deformation by over tightening. A TCG gasket can be used for one side only, if the noncorrosive fluid is running in the other side where a conventional gasket can be used.

### Structure of Fluororesin Cushion Gaskets

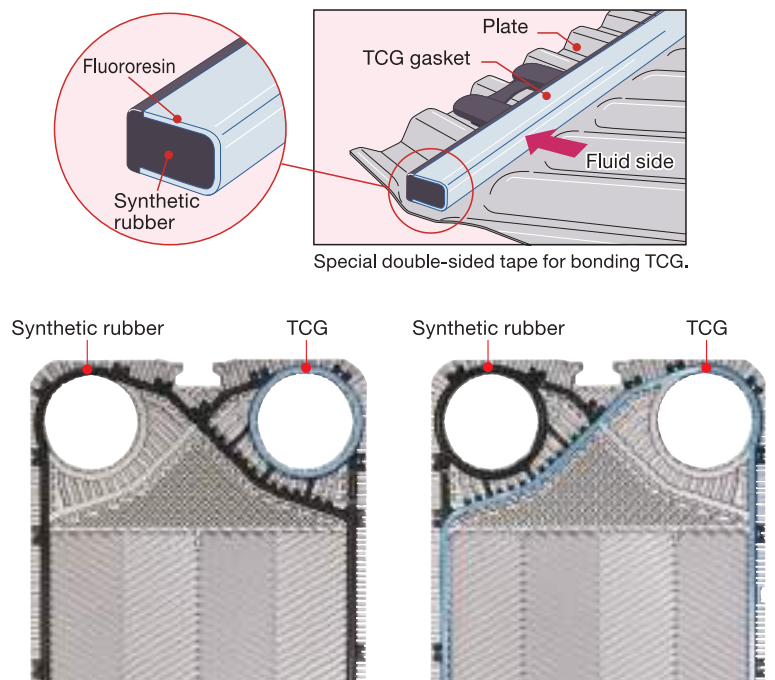



# Dimensions and Weight

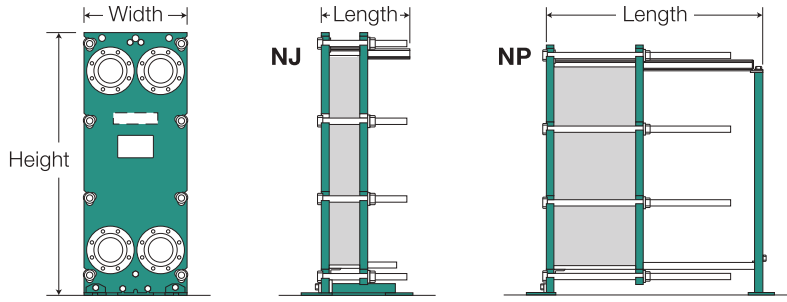

The standard frame is connection type. Piping is connected directly to the S-frame / E-frame using the stud bolts / nuts on the connection holes of the frame.

For the frame model number, refer to P5.

Model	Installation height (mm)	Installation width (mm)	Heat transfer area and installation length / weight (Top: Installation length (mm) / Bottom: Weight (kg))																
			0.2m <sup>2</sup>	0.4m <sup>2</sup>	0.6m <sup>2</sup>	0.8m <sup>2</sup>	1m <sup>2</sup>	5m <sup>2</sup>	10m <sup>2</sup>	15m <sup>2</sup>	30m <sup>2</sup>	60m <sup>2</sup>	100m <sup>2</sup>	200m <sup>2</sup>	500m <sup>2</sup>	800m <sup>2</sup>	1,200m <sup>2</sup>	1,600m <sup>2</sup>	
RX-00	488	242					400												
							50												
RX-10	1,177	460					396	396	396	836	1,036								
							345	380	427	478	615								
RX-30	1,900	650								816	1,216	1,416	1,616						
										1,086	1,222	1,530	1,924	2,932					
RX-50	2,231	950								913	1,113	1,513	2,113	3,513					
										1,983	2,289	2,708	3,730	6,169					
RX-70	2,584	900									1,760	1,760	2,260	4,010					
											2,620	3,030	4,150	7,880					
RX-90	3,140	1,370										1,762	2,012	3,012	4,012	5,512	6,262		
												5,890	6,950	10,280	14,290	19,000	22,350		
LX-00	857	350					418	518											
							170	210											
LX-10	1,066	460					396	396	836	1,336									
							310	364	433	508									
LX-30	1,675	650							816	816	1,016	1,616	2,216						
									1,000	1,050	1,240	1,630	2,160						
LX-50	2,045	810									913	1,113	1,513	2,313					
											1,920	2,350	2,900	4,310					
LX-90	2,418	1,480										1,007	1,257	2,007	4,010	5,510			
												3,830	4,390	5,840	11,200	15,870			
SX-10	1,590	360					426	426	426	426	726	926	1,526						
							280	310	340	390	500	730	1,030						
SX-20	1,870	540								620	820	1,020	1,220	2,020					
										950	1,050	1,250	1,520	2,220					
SX-30	2,683	634								713	913	1,113	1,713	2,913	3,713				
										1,670	1,860	2,120	2,800	4,970	6,170				
SX-40	2,166	805									913	1,113	1,513	3,113					
											2,040	2,400	3,290	6,210					
SX-70	2,692	1,090											1,510	2,510	3,510				
													4,220	6,270	8,750				
SX-80	2,929	1,300											1,757	1,757	2,507	3,757	4,507		
													4,180	5,130	8,160	11,270	14,820		
SX-90	3,410	1,290												3,000	4,000	5,300	6,300		
														8,800	11,200	15,300	18,700		
UX-005	331	160	201	201	209	209													
			14	15	16	18													
UX-10	1,115	408					392	392	832	832	1,032								
							264	300	353	398	556								
UX-30	1,891	610								608	808	1,008	1,608	2,608					
										970									
UX-30L	2,434	582									712	912	1,112	1,712					
											1,110	1,270	1,480	2,000					
UX-90	2,929	1,300												2,757	4,007				
														8,740	13,210				
UX-100	3,780	1,570												2,757	4,007	5,257	6,507		
														12,370	15,990	21,880	26,880		
UX-130	4,300	1,570												2,262	3,012	4,012	4,762		
														13,110	16,520	21,830	26,520		
UX-160	4,250	1,900												2,182	2,852	3,732	4,632		
														23,000	26,140	30,360	34,640		
WX-10	1,222	500					400	832	1,032	1,333									
							449	499	546	716									
WX-50	2,233	820											1,513	2,443					
													3,123	4,190					
WX-90	2,829	1,450													3,300	4,600			
															7,100	10,000			
CX-00	915	346					310	410	510										
							160	180	210										
CX-10	895	346					328	328	638	838									
							170	209	267	325									
CX-20	1,114	470						636	836	1,036									
								370	400	440									
GX-20	1,593	580					933	933	933	1,133	1,933								
							520	640	830	1,000	1,460								

Note: The dimensions and weight are subject to change without notice.

# Plate Types and Dimensions

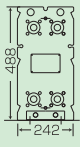
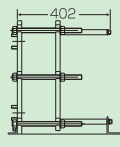
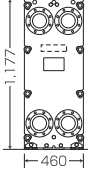
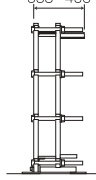
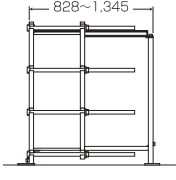
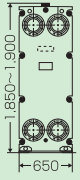
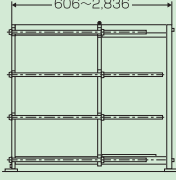
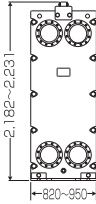
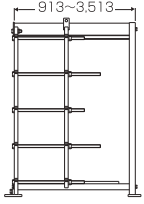
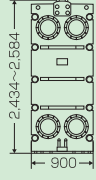
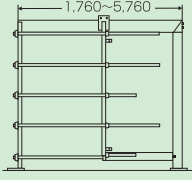
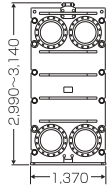
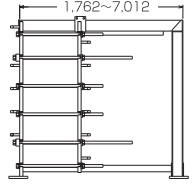
Type	Main specifications		Frame standard type		
			Width and Height	NJ type	NP type
RX-00	Max. flow rate / unit	~20m <sup>3</sup> /h			
	Max. working pressure	2.0MPaG			
	Max. working temperature	180°C			
	Max. heat transfer area / unit	1m <sup>2</sup>			
	Connection Dia.	20A			
RX-10	Max. flow rate / unit	197m <sup>3</sup> /h			
	Max. working pressure	2.7MPaG			
	Max. working temperature	180°C			
	Max. heat transfer area / unit	30m <sup>2</sup>			
	Connection Dia.	100A			
RX-30	Max. flow rate / unit	445m <sup>3</sup> /h			
	Max. working pressure	1.8MPaG			
	Max. working temperature	180°C			
	Max. heat transfer area / unit	200m <sup>2</sup>			
	Connection Dia.	150A			
RX-50	Max. flow rate / unit	923m <sup>3</sup> /h			
	Max. working pressure	2.1MPaG			
	Max. working temperature	180°C			
	Max. heat transfer area / unit	500m <sup>2</sup>			
	Connection Dia.	200A			
RX-70	Max. flow rate / unit	1,286m <sup>3</sup> /h			
	Max. working pressure	1.3MPaG			
	Max. working temperature	150°C			
	Max. heat transfer area / unit	500m <sup>2</sup>			
	Connection Dia.	250A			
RX-90	Max. flow rate / unit	3,167m <sup>3</sup> /h			
	Max. working pressure	1.6MPaG			
	Max. working temperature	130°C			
	Max. heat transfer area / unit	1,600m <sup>2</sup>			
	Connection Dia.	400A			

Note : The above data are subject to change without notice.

# Plate Types and Dimensions

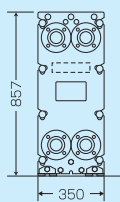
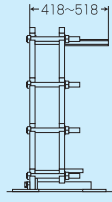
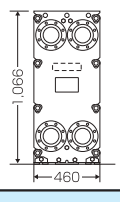
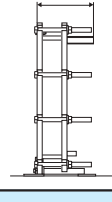
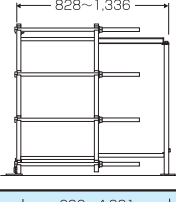
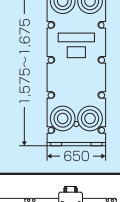
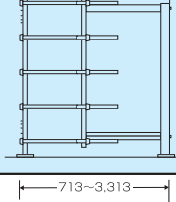
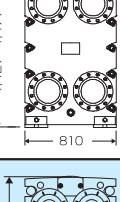
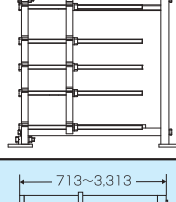
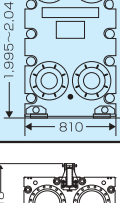
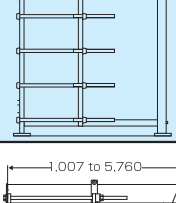
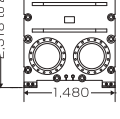
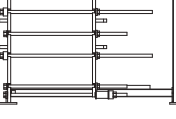
Type	Main specifications		Frame standard type		
			Width and Height	NJ type	NP type
LX-00	Max. flow rate / unit	69m <sup>3</sup> /h			
	Max. working pressure	1.8MPaG			
	Max. working temperature	180°C			
	Max. heat transfer area / unit	5m <sup>2</sup>			
	Connection Dia.	50A			
LX-10	Max. flow rate / unit	197m <sup>3</sup> /h			
	Max. working pressure	1.6MPaG			
	Max. working temperature	180°C			
	Max. heat transfer area / unit	15m <sup>2</sup>			
	Connection Dia.	100A			
LX-30	Max. flow rate / unit	481m <sup>3</sup> /h			
	Max. working pressure	1.25MPaG			
	Max. working temperature	180°C			
	Max. heat transfer area / unit	100m <sup>2</sup>			
	Connection Dia.	150A			
LX-50S	Max. flow rate / unit	791m <sup>3</sup> /h			
	Max. working pressure	1.25MPaG			
	Max. working temperature	180°C			
	Max. heat transfer area / unit	150m <sup>2</sup>			
	Connection Dia.	200A			
LX-50	Max. flow rate / unit	791m <sup>3</sup> /h			
	Max. working pressure	1.25MPaG			
	Max. working temperature	180°C			
	Max. heat transfer area / unit	200m <sup>2</sup>			
	Connection Dia.	200A			
LX-90	Max. flow rate / unit	3,230m <sup>3</sup> /h			
	Max. working pressure	1.6MPaG			
	Max. working temperature	130°C			
	Max. heat transfer area / unit	800m <sup>2</sup>			
	Connection Dia.	400A			

Note : The above data are subject to change without notice.

# Plate Types and Dimensions

Type	Main specifications		Frame standard type		
			Width and Height	NJ type	NP type
SX-10	Max. flow rate / unit	80m <sup>3</sup> /h			
	Max. working pressure	2.0MPaG			
	Max. working temperature	100°C			
	Max. heat transfer area / unit	100m <sup>2</sup>			
	Connection Dia.	50A			
SX-20	Max. flow rate / unit	220m <sup>3</sup> /h			
	Max. working pressure	3.0MPaG			
	Max. working temperature	100°C			
	Max. heat transfer area / unit	200m <sup>2</sup>			
	Connection Dia.	100A			
SX-30	Max. flow rate / unit	445m <sup>3</sup> /h			
	Max. working pressure	3.0MPaG			
	Max. working temperature	100°C			
	Max. heat transfer area / unit	600m <sup>2</sup>			
	Connection Dia.	150A			
SX-40	Max. flow rate / unit	940m <sup>3</sup> /h			
	Max. working pressure	2.4MPaG			
	Max. working temperature	110°C (100°C for some cases)			
	Max. heat transfer area / unit	500m <sup>2</sup>			
	Connection Dia.	200A			
SX-70	Max. flow rate / unit	1,337m <sup>3</sup> /h			
	Max. working pressure	3.0MPaG			
	Max. working temperature	100°C			
	Max. heat transfer area / unit	800m <sup>2</sup>			
	Connection Dia.	250A			
SX-80	Max. flow rate / unit	2,424m <sup>3</sup> /h			
	Max. working pressure	2.0MPaG			
	Max. working temperature	180°C			
	Max. heat transfer area / unit	1,600m <sup>2</sup>			
	Connection Dia.	350A			
SX-90	Max. flow rate / unit	2,565m <sup>3</sup> /h			
	Max. working pressure	2.0MPaG			
	Max. working temperature	130°C			
	Max. heat transfer area / unit	1,600m <sup>2</sup>			
	Connection Dia.	350A			

Note : The above data are subject to change without notice.

# Plate Types and Dimensions

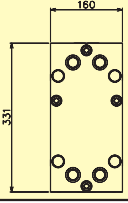
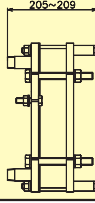
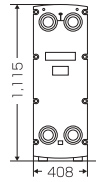
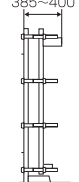
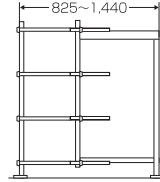
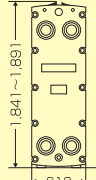
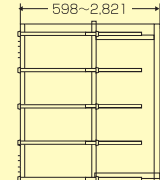
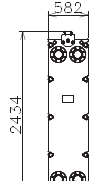
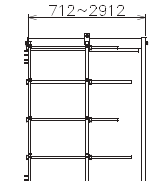
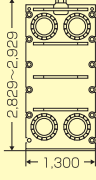
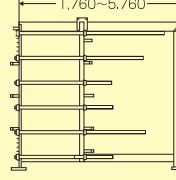
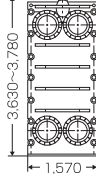
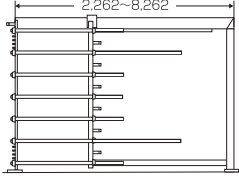
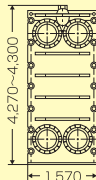
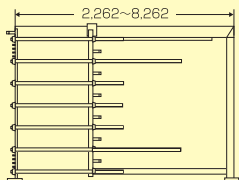
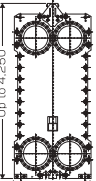
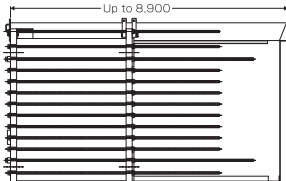
Type	Main specifications		Frame standard type		
			Width and Height	NJ type	NP type
UX-005*	Max. flow rate / unit	15m <sup>3</sup> /h			
	Max. working pressure	0.5MPa			
	Max. working temperature	150°C			
	Max. heat transfer area / unit	0.828m <sup>2</sup>			
	Connection Dia.	20A			
UX-10	Max. flow rate / unit	97m <sup>3</sup> /h			
	Max. working pressure	2.5MPaG			
	Max. working temperature	150°C			
	Max. heat transfer area / unit	30m <sup>2</sup>			
	Connection Dia.	50A			
UX-30	Max. flow rate / unit	285m <sup>3</sup> /h			
	Max. working pressure	2.2MPaG			
	Max. working temperature	180°C			
	Max. heat transfer area / unit	200m <sup>2</sup>			
	Connection Dia.	100A			
UX-30L	Max. flow rate / unit	285m <sup>3</sup> /h			
	Max. working pressure	2.0MPaG			
	Max. working temperature	160°C			
	Max. heat transfer area / unit	400m <sup>2</sup>			
	Connection Dia.	100A			
UX-90	Max. flow rate / unit	2,314m <sup>3</sup> /h			
	Max. working pressure	1.7MPaG			
	Max. working temperature	150°C			
	Max. heat transfer area / unit	800m <sup>2</sup>			
	Connection Dia.	350A			
UX-100	Max. flow rate / unit	4,948m <sup>3</sup> /h			
	Max. working pressure	1.3MPaG			
	Max. working temperature	100°C			
	Max. heat transfer area / unit	1,600m <sup>2</sup>			
	Connection Dia.	500A			
UX-130	Max. flow rate / unit	4,948m <sup>3</sup> /h			
	Max. working pressure	1.3MPaG			
	Max. working temperature	100°C			
	Max. heat transfer area / unit	1,600m <sup>2</sup>			
	Connection Dia.	500A			
UX-160	Max. flow rate / unit	7,300m <sup>3</sup> /h			
	Max. working pressure	2.3MPaG			
	Max. working temperature	100°C			
	Max. heat transfer area / unit	4,300m <sup>2</sup>			
	Connection Dia.	600A			

Note : The above data are subject to change without notice.

\*UX-005 is available in Malaysia standard frame

# Plate Types and Dimensions

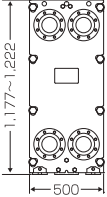
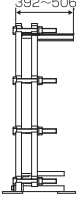
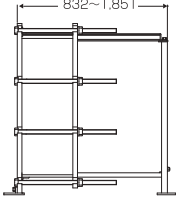
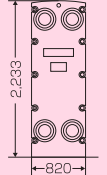
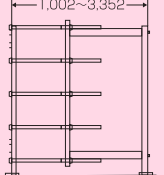
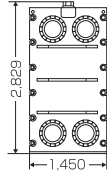
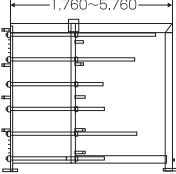
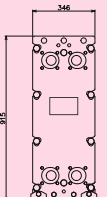
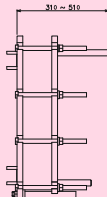
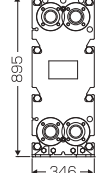
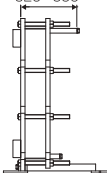
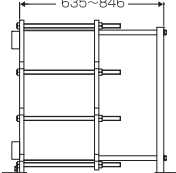
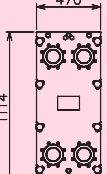
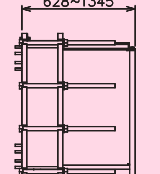
Type	Main specifications		Frame standard type		
			Width and Height	NJ type	NP type
WX-10	Max. flow rate / unit	209m <sup>3</sup> /h			
	Max. working pressure	4.8MPaG			
	Max. working temperature	180°C			
	Max. heat transfer area / unit	30m <sup>2</sup>			
	Connection Dia.	100A			
WX-50	Max. flow rate / unit	791m <sup>3</sup> /h			
	Max. working pressure	4.1MPaG			
	Max. working temperature	180°C			
	Max. heat transfer area / unit	200m <sup>2</sup>			
	Connection Dia.	200A			
WX-90	Max. flow rate / unit	2,208m <sup>3</sup> /h			
	Max. working pressure	2.3MPaG			
	Max. working temperature	150°C			
	Max. heat transfer area / unit	800m <sup>2</sup>			
	Connection Dia.	350A			
CX-00	Max. flow rate / unit	80m <sup>3</sup> /h			
	Max. working pressure	3.20MPa			
	Max. working temperature	150°C			
	Max. heat transfer area / unit	12.3m <sup>2</sup>			
	Connection Dia.	50A			
CX-10* Vertical Horizontal	Max. flow rate / unit	108m <sup>3</sup> /h			
	Max. working pressure	1.9MPaG			
	Max. working temperature	150°C			
	Max. heat transfer area / unit	15m <sup>2</sup>			
	Connection Dia.	50A			
CX-20	Max. flow rate / unit	170m <sup>3</sup> /h			
	Max. working pressure	2.85MPa			
	Max. working temperature	150°C			
	Max. heat transfer area / unit	27m <sup>2</sup>			
	Connection Dia.	100A			

Note : The above data are subject to change without notice.  
 \*CX-10 is both vertical and horizontal installation available.

# Plate Heat Exchanger Lineup

## Condenser / Gas Cooler (YX) Multi Gap Plate (GX)



Cooling water side

Vapor side

YX-83 plate

### Characteristics

- 1 The heat transfer coefficient is about 2 times higher than that of shell & tube heat exchangers. The condensing surface is always secured and the heat transfer coefficient is improved because condensate is immediately drained out.
- 2 Special considerations are taken for the plate characteristics in order to achieve a much lower vapor pressure drop than conventional Plate Heat Exchangers.
- 3 The cooling water consumption is about half that of S&T heat exchangers.
- 4 TCG gaskets are selectively used to permit a wide range of applications.
- 5 Less maintenance work, as the plates can be easily cleaned and inspected.
- 6 The vapor connection sizes holes are the same for the inlets and outlets, allowing for use as a cooling condenser for vapor with inert gas.
- 7 Various international Pressure Vessel Code and Standard such as ASME, JIS, CE available.

### Applications

- 1 Overhead condensers for various distillation columns
- 2 Condensers / preheaters for evaporators
- 3 Condensers for gas drying / air conditioning
- 4 Heat recovery exchangers from exhaust steam
- 5 Gas coolers, etc.

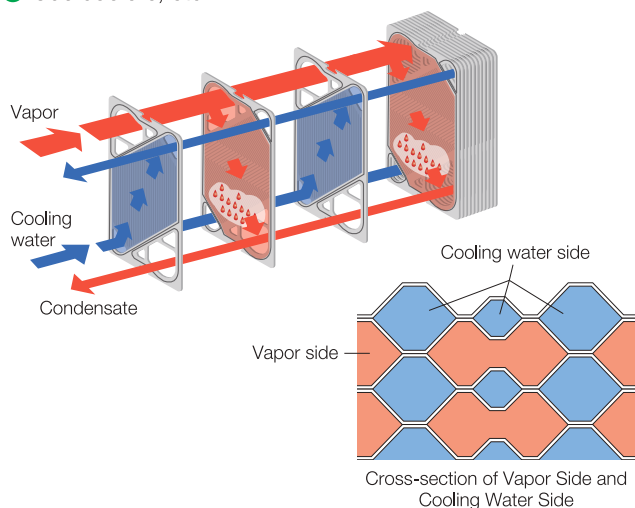

Vapor side

Cross-section of Vapor Side and Cooling Water Side

By combination of one plate arrangement gives 3 multiple-channel configuration.

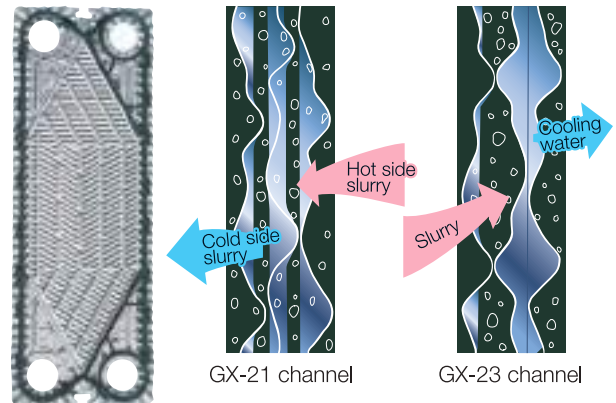

GX-20

(By reversing and upside-down GX-21 to GX-22.)

GX-21 channel

GX-23 channel

### Characteristics

- 1 Easy for fluids containing solids to flow between wide gap channels (10 mm).
- 2 A combination of plates provides the widest channel spacing (20 mm).
- 3 It provides better performance for slurry, sludge and liquid containing crystals.
- 4 Electrolytic polishing selectively used for food applications.
- 5 Shorter maintenance time due to the slit-in gasket.

### Applications

#### 1 Chemicals

- Fluids containing solids: Polyvinyl chloride (polymer), various slurry fluids
- High viscosity fluids: Rubber latexes, resin latexes

#### 2 Dyeing

- Fluids containing fibers: Waste fluid from Dyeing machine
- High viscosity fluids: Viscose

#### 3 Food

- Fluids containing solids: Sauce for grilled meat, juice with fiber, factory waste water
- Fluids containing fibers: Amazake
- High viscosity fluids: Mayonnaise, various sauces, starch saccharification liquid, syrup

#### 4 Sugar

- Fluids containing solids: Raw juice, sugar making process such as the Steffen process, processed fluids, factory waste water

#### 5 Pulp and paper

- Fluids containing fibers: Diluted black liquor, white liquor

#### 6 Other

- Plating fluid containing sludge, quenching oil
- High concentration sodium hypochlorite, sodium aluminate
- Heat transfer for significantly different flow rates on the hot / cold sides plant
- Snow melting plant

# Plate Heat Exchanger Lineup

## Exclusive Food Application Plate (FX)

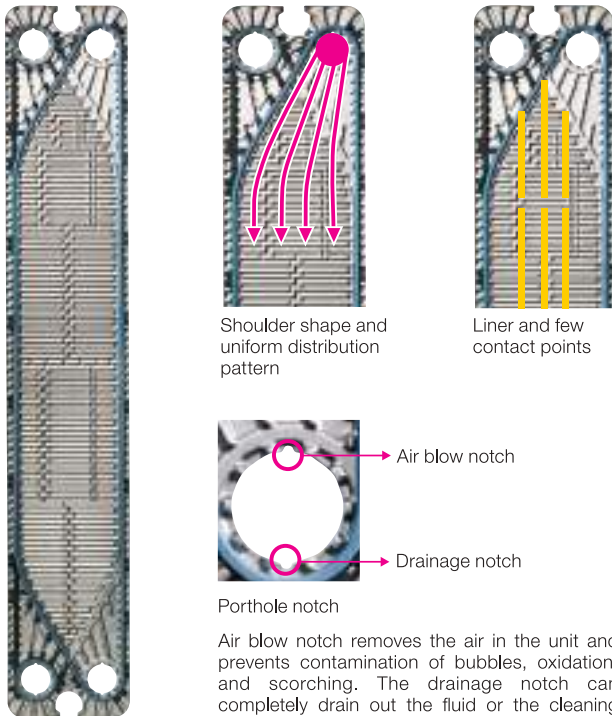

### Characteristics

- 1 The uniform distribution pattern and the shape of the shoulder section are smoothed to create a uniformly smooth flow through the plate channels, enabling product-gently heat transfer with a uniform, and even temperature in the unit.
- 2 The plate contact points have been significantly reduced to 1/4th of the conventional pattern, and the liner and few contact points arrangement has a self-cleaning effect. For that reason, long-term operation is possible, as it is less to clogs, scales and partial scorching than conventional type.
- 3 The piston flow in the plate channels reduce the fluid replacement time to 1/4th of the conventional type, significantly reducing the product loss by 75%.
- 4 There is also little dead space within the channels and holding volume is small, achieving a high CIP effect.
- 5 The slit-in type TCG gasket also prevents rubber smells / glue smells in the product and remain scents when switching products to be produced.

### Less Product Loss

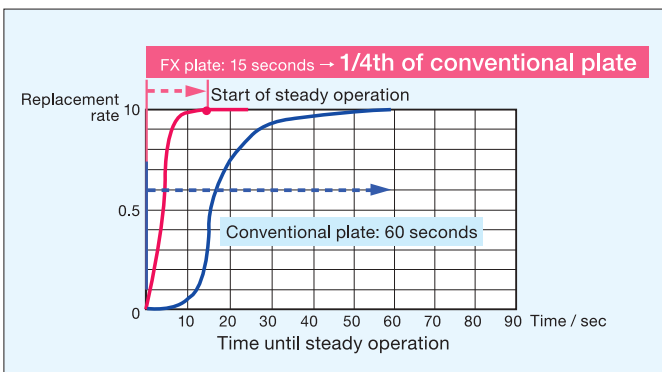

## Dual Wall Plate

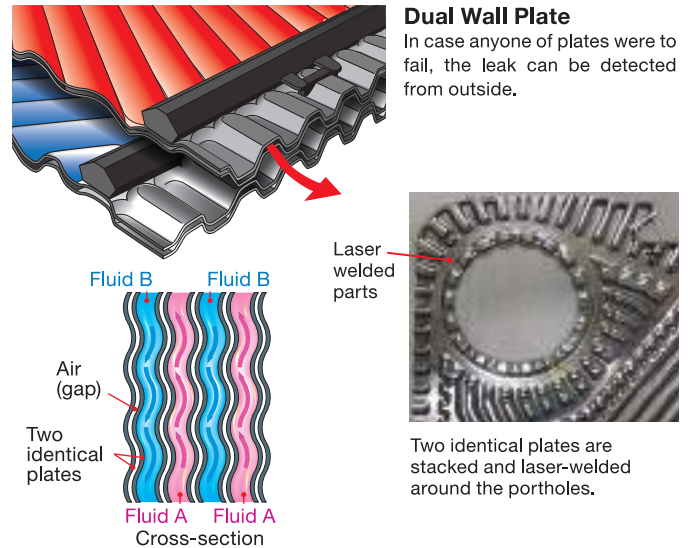

The dual wall plate heat exchangers use to achieve "relief and reliance" for preventing contamination of the two fluids.

### Characteristics

- 1 The dual wall design prevents any leaks from going farther due to the air gap and the second plate. In case any one of plates were to fail, the leak can be detected from outside because of leaking through the gap of the plates.
- 2 To prevent intermixing of the fluids, "Double seal gasket" (refer to P6) system is used. Any leakage of fluids across the gasket can be detected from the outside because the liquid escapes from the units.

### Applications

- 1 Cooling of transformer oil, which might explode if mixed with the cooling water
- 2 Cooling of lubrication or hydraulic oil, which can damage the rotator or hydraulic equipment if mixed with the cooling water
- 3 Heating / cooling of food processing, where there must be no mixing of foreign materials in the product
- 4 Heating / cooling of fuel oil (marine gas oil: MGO) where fatigue breakdown due to highly frequent pulsation
- 5 Heating / cooling in bio-process where the process fluid may cause environmental pollution
- 6 Heating / cooling between fluids where mixing can cause a sudden chemical reaction or generate environmental pollutants

It is normally necessary to install two heat exchangers where it is dangerous if fluid A and fluid B are mixed. However, with the dual wall plate, this is possible with just one unit.

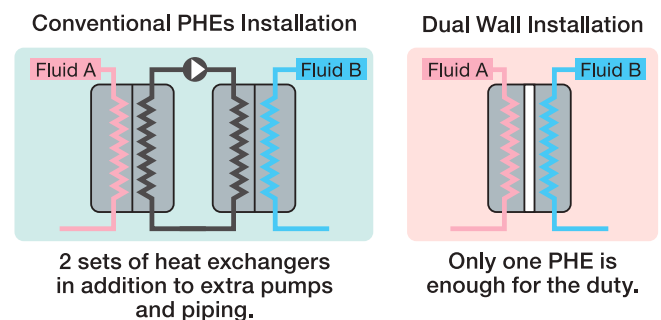



## Double-lined Gasket Plate Hestia NX-50

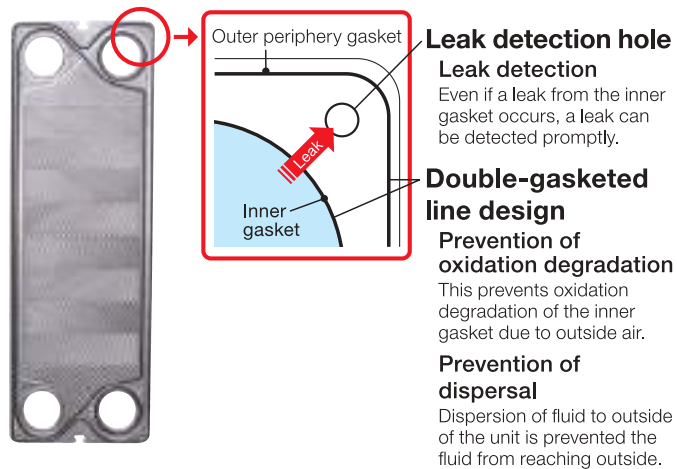

### Characteristics

- 1 The double-gasketed line design provides a gasket line to the outermost periphery to inhibit oxidation degradation in the inner gasket (which serves as a seal) from outside air.
- 2 It prevents leakage dispersal. Should a leak occur in the inner gasket, this prevents the fluid from reaching outside.
- 3 To achieve high heat-resistance, the compounding ratio of the gasket has been improved.
- 4 The improved gasket groove and plate pattern increase seal pressure and ensure high pressure-resistance.
- 5 It achieves a life time 5 times longer than Hisaka's conventional Plate Heat Exchangers.
- 6 High heat-resistance and pressure-resistance allow for environments with high temperature of 250°C and seal pressure of 9.5MPa or higher, which conventional PHE couldn't use.

### Applications

- 1 High temperature / High pressure fluids  
 High temperature, high pressure heat exchangers around boilers or the like  
 Heat exchangers in conventional / nuclear power applications
- 2 Dangerous fluids  
 Heat exchangers for flammable and dangerous fluids in locations such as chemical plants

### High-Heat / High-Pressure Resistance

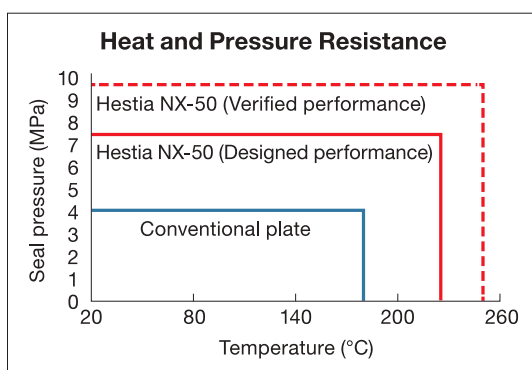

\* The Hestia NX-50 was developed jointly with Hitachi-GE Nuclear Energy, Ltd.  
 \* Patent pending

## Semi-welded Plate (WX)

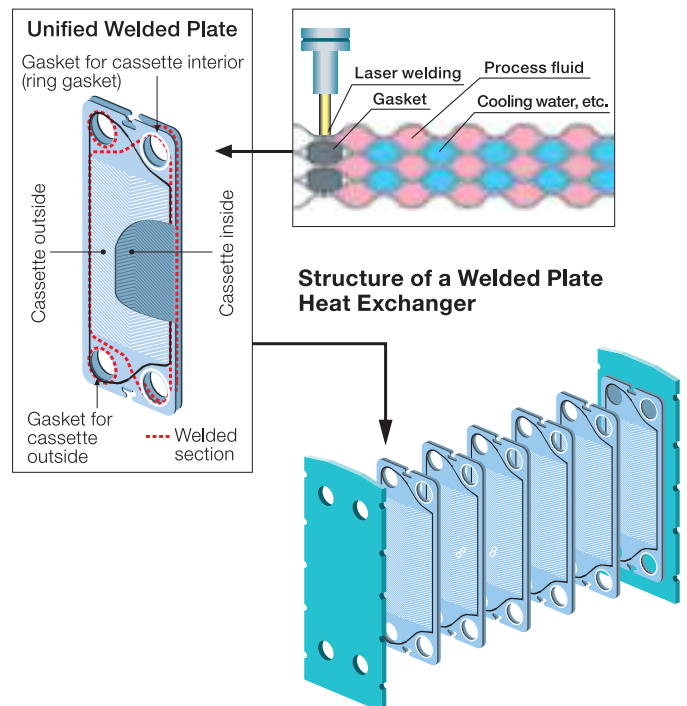

### Characteristics

- 1 A couple of plates are laser welded with o-ring at portholes between the plates. One fluid flowing through the inside of the cassettes and the other fluid flowing on the outside of the cassettes.
- 2 As disassembly is possible for each plate cassette, both sides of the plate cassette can be cleaned.
- 3 As plate cassettes is sealed by laser welding except the portholes, this product is fit for high pressure duty, Freon refrigerants or fluids that corrode synthetic rubber.
- 4 There are two types of ring gaskets; a synthetic rubber, and PTFE gasket (TCG) with outstanding chemical resistance.

### Applications

- 1 Heating / cooling of fluids that corrode synthetic rubber
- 2 Heating / cooling of dangerous fluids such as sulfuric acid
- 3 Heating / cooling for the duty exceeding the heat or pressure resistance of gasket-type plate heat exchangers
- 4 Heating / cooling in refrigeration cycles using refrigerant

### Specification

	Conventional model	Welded model
Pressure resistance	Up to 3.0 MPaG	Up to 4.0 MPaG
Heat resistance	150°C	180°C

# Plate Heat Exchanger Lineup

## Welded Plate Heat Exchangers

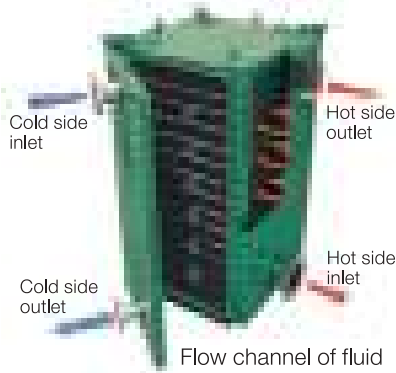

### Variety of plate gap

- 

(1) Both sides lightly charged fluid  
**HXC**  
 Both sides corrugated channel.
- 

(2) One charged fluid  
**HXC Free Flow (FF)**  
 FF corrugated / corrugated channel.
- 

(3) One side highly charged fluid  
**HXE**  
 FF / Dimpled channel.
- 

(4) Both sides dirty fluids  
**HXS**  
 Both side rectangular FF channel with studs.

\*Free Flow: Wide gap and no contact point between the heat transfer plates

### Characteristics

- 1 The press-molded plate is molded with a special corrugation pattern to ensure a high transfer coefficient.
- 2 It supports high temperatures and high pressures, showing its performance in a wide range of fields.
- 3 The seal gasket consists only of the side cover, so there are virtually no restrictions due to gasket materials.
- 4 As baffles can be installed to enable a multi-pass design, heat transfer performance is close to a counter-current flow, and has a flexible flow rate.
- 5 As the holding volume is small, the amount of fluid remaining in the unit is also small and only a small amount of CIP detergent can be used.
- 6 Easy mechanical cleaning by the cross flow channel structure.

### Applications

- 1 Heat transfer process for higher efficiency than Shell & Tube heat exchangers
- 2 Heat recovery in high temperature / high pressure applications
- 3 Condensers
- 4 Vaporizers
- 5 Heat transfer process where a Gasketed PHE cannot be used

They are also able to replace Shell & Tube heat exchangers in other cases as well.

### Specification

Max. working pressure	3,5 [MPaG]
Max. working temperature	Up to 350 [°C]
Connection size	50A to 600A
Max. heat transfer area	Up to 700 m <sup>2</sup> /unit
Plate material	Stainless steel, titanium, high nickel alloy

\* The above mentioned varies depending on the operating conditions. Please inquire with our company when planning.

## Brazed Plate Heat Exchangers

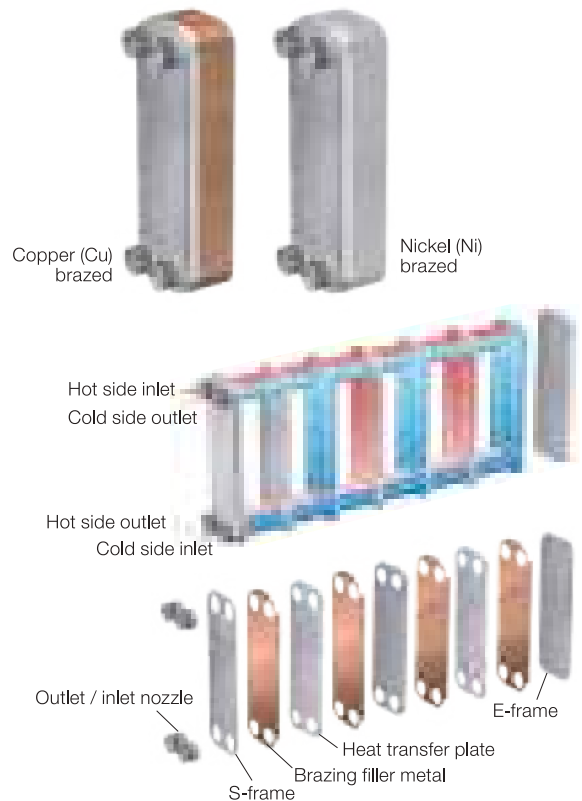

### Characteristics

- 1 Brazed plate heat exchangers are brazed stainless steel plates by brazing filler metal such as copper or nickel.
- 2 It is high performance and allows for a small heat transfer area.
- 3 Due to the small heat transfer area and the thin material by sturdy brazed structure, light weight, and compact design are achieved.
- 4 With brazed structure, it provides a high level of sealing and outstanding heat and pressure resistance.
- 5 The brazed structure reduced material to minimum is fit for mass production and is economically outstanding.

### Applications

- 1 Vaporizers / condensers of refrigerant in compression refrigeration cycles (refrigerators / heat pumps)
- 2 Solution heat exchangers for absorption refrigerators
- 3 Industrial and home water heaters
- 4 Heat recovery heat exchangers for cogeneration systems or gas heat pumps
- 5 Oil coolers for hydraulic equipment
- 6 Heat exchangers for temperature control of various industrial equipment and medical examinations

### Specification

Design pressure: F.V. to 4.5 MPa  
 Design temperature: -100°C to 200°C

\* The above mentioned varies by model. Please inquire with our company when planning.

# Maintenance Menu

## PHE Total Maintenance [Full Service Package] from pickup to assembly

The Full Service Package is a total maintenance service in HISAKA. PHE disassembly, visual checks of plates, cleaning, regasketing, frame repairs, assembly, and final inspection are all performed by service centers, for the best possible performance and a long operating life time for PHEs. We also offer the "Full Service Package" for plates only.



### Return Containers for "Full Service Package" for plate only (Optional)



Return containers that precisely fit the plates that are currently in use are provided upon customers' request.

## On-site Maintenance

HISAKA can send skilled service engineers to perform maintenance work at the customer's site. We use specialized tools, such as automatic tightening devices, to efficiently disassemble and assemble the PHE and high temperature hot water jet cleaning to remove sticky oil residues, providing high quality maintenance service at the customer's site.



## Cleaning In Place (CIP)

Disassembly and cleaning a PHE makes it possible to remove hard scale and clogging matters and to recover performance to nearly the same level as new. However, if disassembly and cleaning are not possible, HISAKA offers CIP using "Plate-Clean" at customers' site. Before scaling, CIP with Plate-Clean can restore performance by removing scale through washing and dissolving. This is effective in prolonging the disassembly cleaning cycle of the PHE. This is effective for extending the disassembly cleaning cycle of plate heat exchangers.

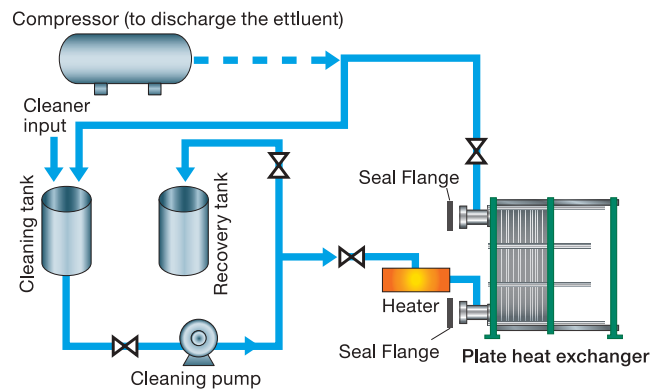

CIP Flow Chart

## Plate-Clean

Plate-Clean is a special cleaner for PHEs. By circulating the cleaner inside the PHE, stubborn scale that forms on the cooling water, warm water, and steam sides can be easily removed by cleaning and dissolving without disassembling the unit. Customers are no longer required to perform the hard work of removing scale.

### Cleaner and Target Scale

	Product Name	Target Scale
Cleaner	Plate-Clean C	Calcium carbonate
	Plate-Clean S	Slime, mud
	Plate-Clean F	Iron rust

### Plate-Clean Series



\* Each type of Plate-Clean is also sold separately.

# Plate Heat Exchangers Used in Various Applications

## Chemicals



Soda, fertilizer, petrochemistry, petroleum refining, oil and fat, chemicals, general inorganic / organic chemical industry, etc.

## HVAC



Heating / cooling system, water heating, district heating / cooling, building heat storage tank systems, unused energy

## Gas Treatment



CO<sub>2</sub> recovery, desulfurization plant solution heat exchange

## Metal and Mining



Sulfuric acid, electrolytic plating cooling

## Iron and Steel



Blast furnace cooling, continuous casting equipment cooling, COG, various plating fluid cooling

## Pulp & Paper



Heat exchange of black liquor / white water, oven blow gas condensation, waste heat recovery

## Marine



Cooling of engine jacket water and lubricant oil

## Electric Power



Generators, cogeneration

## Environment



Solvent recovery, exhaust gas cooling

## Central Cooling



Central cooling system

## Food



Beer, edible oil, sodium glutamate

## Fermentation and Distillation



Brewing, alcohol fermentation process such as for bioethanol

# Global Network※

## ● HISAKA Group

### ■ Malaysia

**HISAKAWORKS S.E.A. SDN. BHD.**  
**KUALA LUMPUR**

TEL: +60-3-8081-4185 FAX: +60-3-8081-7185  
E-mail : heatexc@hisaka-asia.com

### JOHOR BRANCH

TEL : +60-16-228-4209  
E-mail : cswong@hisaka-asia.com

### ■ Thailand

**HISAKA WORKS (THAILAND) CO., LTD.**  
**BANGKOK**

TEL: +66-2-744-3287 FAX: +66-2-744-3286  
E-mail : heatexc@hisaka-thai.com

### SATTAHIP SALES OFFICE

TEL: +66-3-819-9819 FAX: +66-3-819-9820  
E-mail : heatexc@hisaka-thai.com

### ■ Singapore

**HISAKAWORKS SINGAPORE PTE. LTD.**

TEL: +65-6-897-8489 FAX: +65-6-686-4579  
E-mail : heatexc@hisaka-sing.com

### ■ Indonesia

**PT. HISAKA WORKS INDONESIA**  
**JAKARTA**

TEL: +6221 2295 9806/9807 FAX: +6221 2931 9333  
Email : hisakindo@hisaka-asia.com

### ■ Vietnam

**HISAVINA Ho Chi Minh (Representative Office of HISAKAWORKS S.E.A. SDN. BHD.)**

TEL: +84-8-3910-7355 FAX: +84-8-3910-7356  
E-mail : hisavina@hisaka-asia.com

### ■ Philippines

**HISAPINO Manila (Representative Office of HISAKAWORKS S.E.A. SDN. BHD.)**

TEL: +63-2-224-4129 FAX: +63-2-224-4130  
E-mail : hisapino@hisaka-asia.com

### ■ South Korea

**HISAKA KOREA CO., LTD.**  
**SEOUL**

TEL: +82-2-739-8861 FAX: +82-2-739-8864  
E-mail : heatexc@hisakakorea.com

### BUSAN BRANCH

TEL: +82-51-747-0265 FAX: +82-51-747-0266

### ■ China

**HISAKA WORKS(CHINA)CO., LTD**  
**CHANGSHU**

TEL: +86-512-5213-3000 FAX: +86-512-5213-3008

### SHANGHAI BRANCH

TEL: +86-21-5211-0701 FAX: +86-21-5211-0720  
E-mail : hisaka-sha@hisaka.co.jp

### GUANGZHOU BRANCH

TEL: +86-20-3810-5515 FAX: +86-20-3847-7539

### NANJING SALES OFFICE

### ZHUHAI SALES OFFICE

### NINGBO SALES OFFICE

### ■ Saudi Arabia

**HISAKA MIDDLE EAST CO., LTD.**  
**DAMMAM**

TEL: +966-13-838-4700 FAX: +966-13-838-5800  
E-mail : info@hisaka-me.com

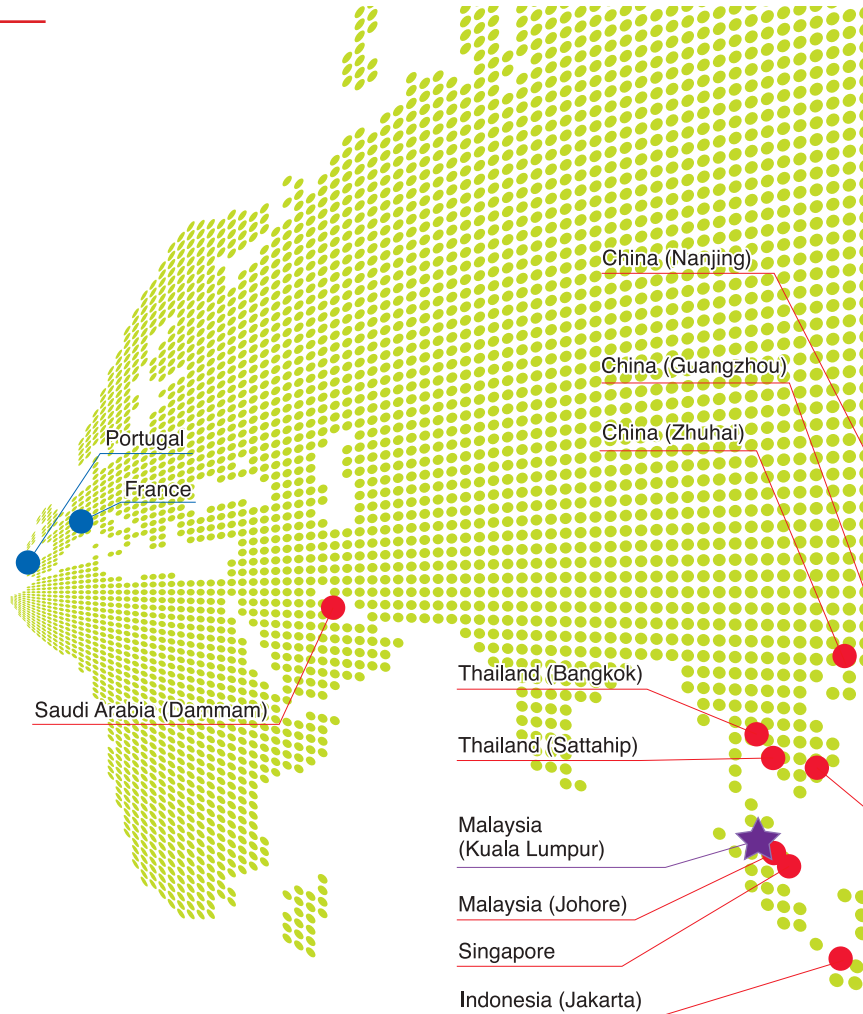

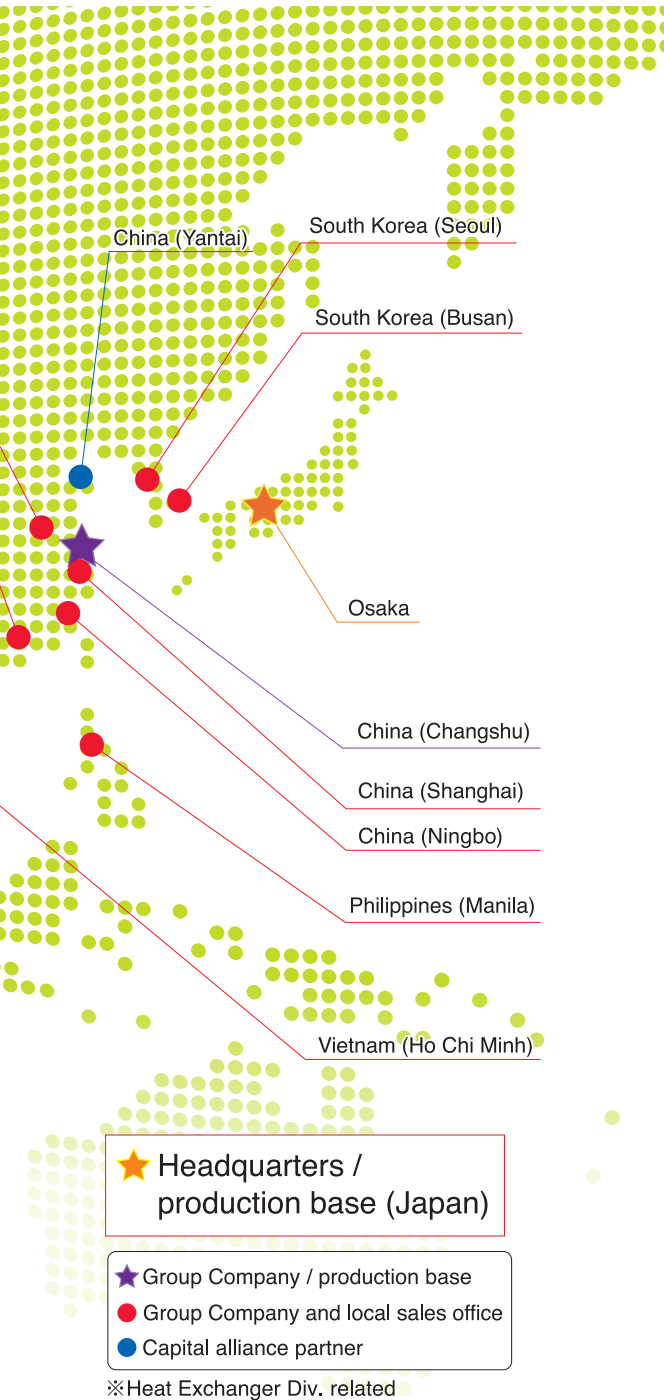

● **Capital alliance partner**

**ARSOPI THERMAL S.A. (Portugal)**

TEL: +351-256-410-410 FAX: +351-256-410-411

**YANTAI SHINWA JOINT TECHNOLOGY CO., LTD. (China)**

TEL: +86-535-643-3939 FAX: +86-535-643-3926

**KAPP SAS (France)**

TEL: +33-4-78-05-68-68

● **HISAKA Maintenance Network**

■ **Malaysia**

**HISAKAWORKS S.E.A. SDN. BHD.**

No2, Jalan TP2, Taman Perindustrian SIME UEP, 47600 Subang Jaya, Selangor Darul Ehsan, Malaysia  
 TEL: +60-3-8081-4185 FAX: +60-3-8081-7185

■ **Singapore**

**JECS SINGAPORE (PTE) LTD.**

26, Gul Drive, Jurong Town, Singapore 629474  
 TEL: +65-6-861-5577 FAX: +65-6-861-4253

■ **Indonesia**

**PT UNGGUL PRAKARSA PRISMA**

Jl. Industri Selatan 8, Blok EE-8E, Kawasan Industri Jababeka 2, Cikarang Bekasi 17550, West Java  
 TEL : +62-21-8984-1348

■ **South Korea**

**CLEANPIA.s**

187, Sunhwan-ro, Jungwon-gu, Seongnam-si, Gyeonggi-do, 13207, Republic of Korea  
 TEL : +82-1877-5335

■ **China**

**HISAKA WORKS (CHINA) CO., LTD., Changshu Plant**

No. 1 Xiangyuan Road, Changshu New & High-tech Industrial Development Zone, Changshu City, Jiangsu Province 215542, P.R. China  
 TEL : +86-512-5213-3000

■ **Saudi Arabia**

**HISAKA MIDDLE EAST CO., LTD.**

P.O Box: 7102, Dammam 32435, Building No. 3861, Al Khudhariya Industrial Area, Dammam Saudi Arabia  
 TEL : +966-13-838-4700

■ **Portugal**

**ARSOPI THERMAL S.A.**

P.O. Box 103, Codal 3730-901, Vale de Cambra, Portugal  
 TEL : +351-256-410-410

# Online Simulator

## HISAKA Web-Simulator (HWS)

This is the first plate heat exchanger design website opened on the Internet in the world.  
Access the URL below and click on the Web-Simulator icon.

You can simulate the plate heat exchanger perfect for your needs, any time of the day, from anywhere.



[https://www.hisaka.co.jp/simulator\\_english/](https://www.hisaka.co.jp/simulator_english/)

## Quotation Request by FAX

Malaysia Fax :+60 3 8081 7185

If necessary to help for selection of Plate Heat Exchanger, please fax the form below to us.

1. Heat duty	kW	
	Hot side	Cold side
2. Fluid name		
3. Inlet temperature	°C	°C
4. Outlet temperature	°C	°C
5. Flow rate	m <sup>3</sup> /h	m <sup>3</sup> /h
6. Pressure loss	MPa or less	MPa or less
7. Maximum working pressure	MPaG	MPaG
8. Special notes Plate materials, gasket materials, etc.		

### HISAKAWORKS S.E.A SDN. BHD.

(Company No. 200401032551)

#### SOUTH EAST ASIA HEADQUARTERS

No. 2, Jalan TP2, Taman Perindustrian SIME UEP,  
47600 Subang Jaya, Selangor, Malaysia  
Tel : +603 8081 4185 / +603 8081 1634 - 5  
Fax : +603 8081 7185  
Email : heatexc@hisaka-asia.com

#### JOHOR OFFICE

30-02, Jalan Molek 1/10,  
Taman Molek, 81100 Johor Bahru, Johor.  
Tel : +6016 228 4209  
Fax : +607 351 6840  
E-mail : cswong@hisaka-asia.com

### VIETNAM REPRESENTATIVE OFFICE

#### HO CHI MINH CITY

Hoang Dan Building, 47-49 Hoang Sa Street,  
Da Kao ward, District 1, HCMC, Vietnam.  
Tel : +84-28-39107355  
Fax : +84-28-39107356  
Email : hisavina@hisaka-asia.com

### PHILIPPINES REPRESENTATIVE OFFICE

Level 10-1, One Global Place, vOffice,  
25th St. & 5th Ave., Bonifacio Global City,  
Taguig City 1632 Philippines  
Tel : (+632) 224-4129  
Fax : (+632) 224-4130  
Email : hisapino@hisaka-asia.com



### The Thermal Solution Company

Using plate type heat exchangers as our core technology, HISAKA WORKS provides thermal solutions to our customers all over the world.

No part of this brochure may be used, cited, or altered for any purpose or reproduced in any form without the prior written permission of the copyright holder.  
All product details, including appearance and specifications, presented in this brochure are subject to change for improvement without prior notice.

Agent